

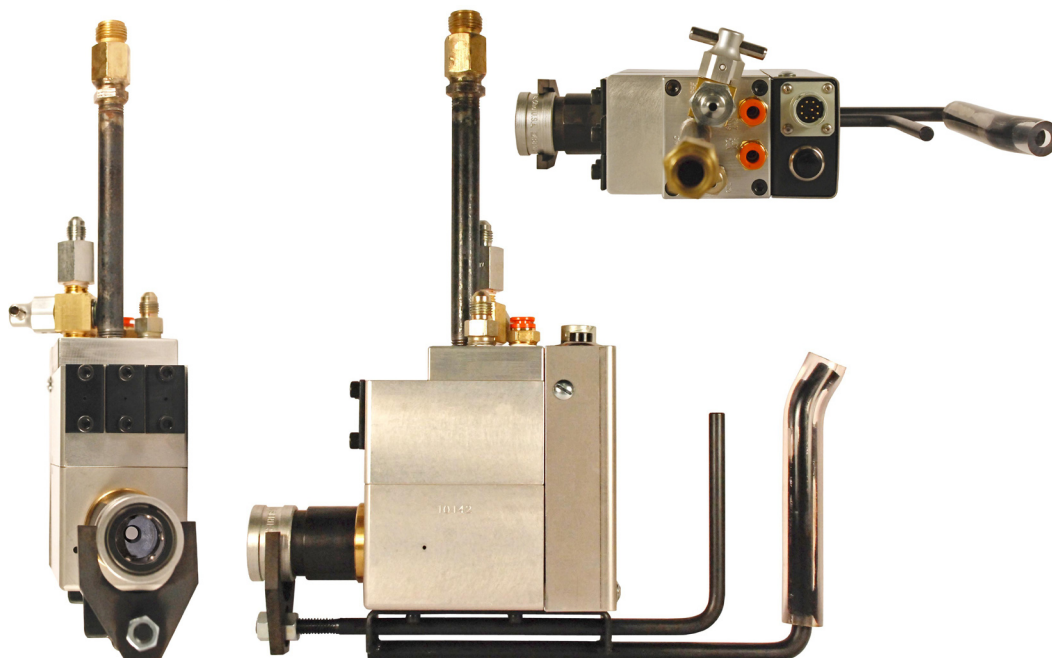

Series 300 Evacuation & Refrigerant Charging Tool

FEATURES

- Minimum refrigerant loss
- Manual disconnect
- High vacuum & refrigerant flow rates
- Lightweight
- Connection to J639 High-Side fitting
- Relief style refrigerant & oil valve
- Air operated vacuum valve
- Easily adapted to different style process fittings
- Easily modified for multiple refrigerants
- Optional selector switch for multiple charge size
- Independent stem operation
- Scavenge optional



The PCU Series 300 A/C Charging Tool is part of an automated charging system designed to process the A/C system on appliances and vehicles. The system normally consists of a charger which provides a fast precise method of dispensing refrigerant, along with product vacuum checking prior to charging. A line accumulator and/or booster pump which maintain a consistent refrigerant supply.

The automatic 3 valve charging tool, hose, and control cable assembly permits tool connection evacuation, automatic process coupler valve actuation, unit vacuum checking as well as refrigerant and oil charging through a single connection to the product.

The tool oil and refrigerant valves are of the relief type they open and close in accordance with fluid pressure as provided by the charger. The vacuum valve and process coupler valve actuator are operated by spring backed air pistons. The tool is normally adapted for use with the

PCU series 250 process coupler. However other process couplers are available. This tool is electrically heated and thermostatically controlled at a temperature of 112°F (33°C) to prevent condensation of moisture on the coupler and to force refrigerant liquid from the connector into the unit at the end of the cycle. The charging machine cycle "Start" switch is usually mounted on the tool assembly and tool is normally supported by a tool balancer.

To operate the tool, the operator squeezes the handles, positions the tool on the process fitting and releases the handles, and then depresses the cycle "Start" pushbutton on the tool. Afterwards the evacuation cycle, vacuum check and refrigerant charging takes place automatically.

Contact our Order Department (1-937-299-5594) with your application and equipment specifications.

Series 300 Evacuation & Refrigerant Charging Tool

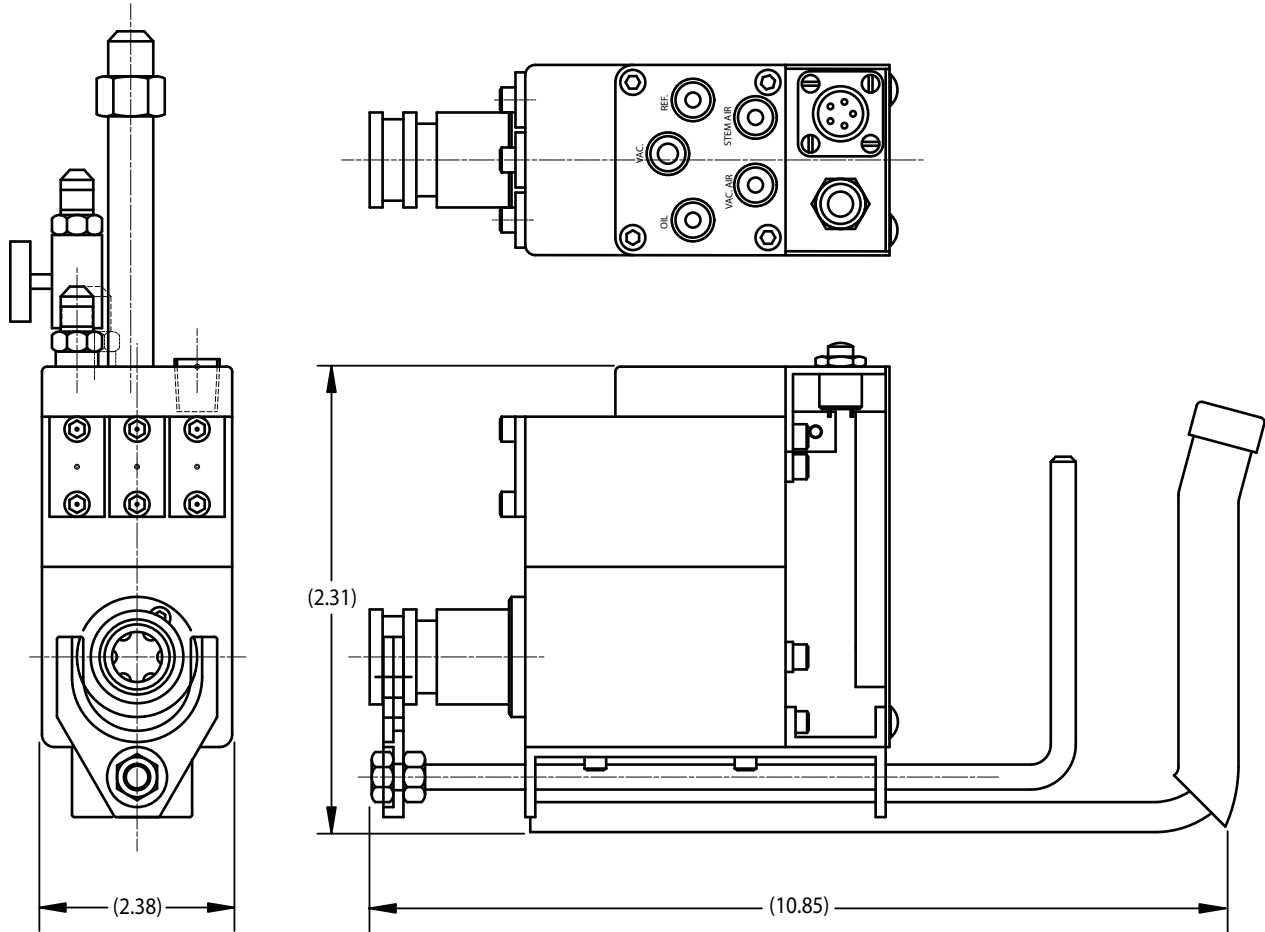

TECHNICAL SPECIFICATIONS:

Weight	7.2 lbs (3.27 kg)	Process fitting compatibility	Series 250 (Optional Series 410 Hansen 2HK, 3HK, 4HK)
Vacuum range	0-760 TORR (0-760 mmHg)	Process fitting nose seal	O-Ring
Vacuum port fitting	1/2" SAE	Process fitting clamp system	PCU BalLoc
Refrigerant port fitting	1/4" SAE	Oil compatibility.	Polyolester or PAG
Min. Oil Charge Pressure.	480 PSIG	Electrical Connection	9 or 12 Pin Receptacle
Min. Refrigerant Charge Pressure.	480 PSIG		
Air pilots	(Vacuum & Stem air)		
Air supply pressure	60 PSIG (4.2 kg/cm ²)		
Stem Air port fittings	1/4" SAE FL (Optional 1/4" Dia one touch fittings)		



Production Control Units, Inc.

2280 West Dorothy Lane, Dayton, Ohio 45439-1892 Phone (937) 299-5594 FAX: (937) 299-4843
 ©Production Control Units, Inc. U.S.A. Web: www.pcuinc.com