

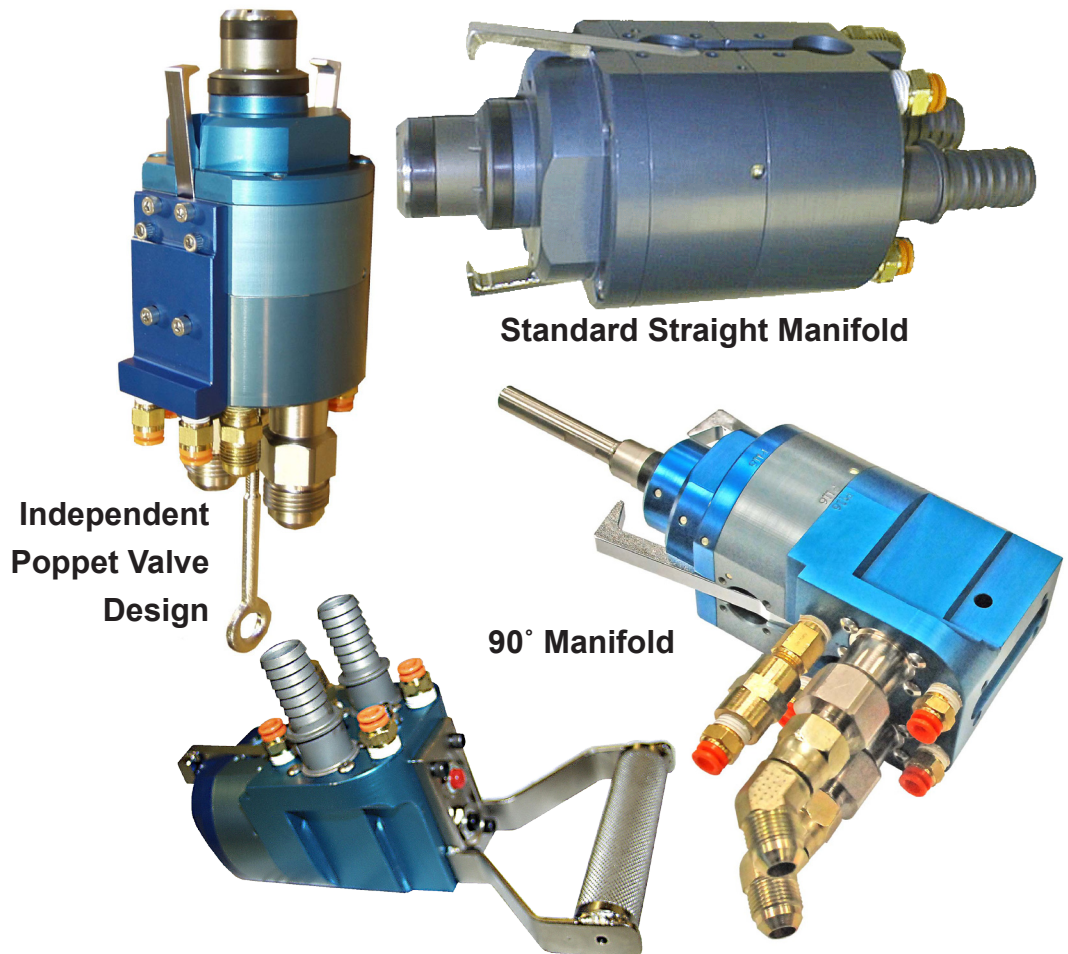

Series 106 Radiator Fill Tool

FEATURES

- Simple attachment
- Air operated valve
- Dry evacuation circuit
- Drip free operation
- High vacuum flow rate
- High coolant flow rate
- Automated disconnect
- Fail safe operation
- Rugged & durable construction
- Easily maintained
- Light Weight



The PCU Compufill Series 106 Radiator Fill Tool connects to engine cooling systems for evacuation and filling. This tool adapts the filling equipment to the cooling system.

The PCU Compufill Series 106 tool can be operated in conjunction with all PCU and other compatible radiator fill machines. This series of tools includes models which can be attached to most common radiator fill necks and surge tank inlets.

Typical tool operation is semi-automatic in that the operator has only to locate the tool onto the fill neck. Upon initiation of the fill cycle, the tool, under control of the fill machine will automatically seat and seal in order that the evacuation, leak

check, filling, and fill quality operation can proceed. Upon completion of these operations, the tool unseats and can then be retracted. All models are designed to provide minimum drip operation.

The PCU Compufill Series 106 tool provides flexibility from manual operations to those which are fully automated when attached to an tool presentation arm.

Series 106 tools can be easily modified for power steering, fuel, and transmission applications. Contact our Order Department at (1-937-299-5594) for your application requirements.

Series 106 Radiator Fill Tool

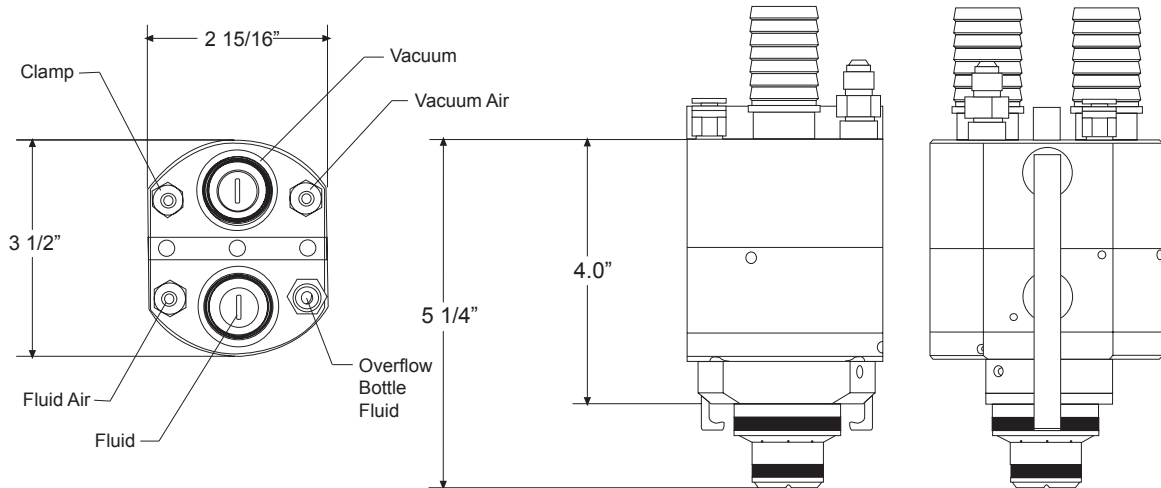

- Tools can be used with PCU tool presentation arms for manual connect - pick and place - semi-auto attachment to vehicle reservoirs.
- Fits large and small radiator necks and all size surge tanks.
- Large internal porting for high flow rate.
- Tool designs for volume or pressure fill.
- Tools are built with spring returns on the valve ports for fail-safe operation during power loss.
- Tool design includes the ability to fill the overflow bottle during the normal cycle.
- All phases of evacuation and fill cycle internal to tool are automatically controlled by the evacuate and fill machine.
- Tools are compatible for operation with programmable logic, relay, or computer based control systems.
- Interfaces to the Compufill Series 106 tool include clamp, seal and valve control air, coolant mixture and vacuum.
- A robust design and durable construction work well in a constant use production environment.
- Aluminum and stainless steel construction are used to minimize weight and eliminate corrosion.

TECHNICAL SPECIFICATIONS:

Weight 3.25 lbs (1.5 kg)	Maximum Fluid Pressure. 50 psi
Fluid. Engine Coolant	Radiator/Surge Tank Common sizes for Rad & Surge Tanks
Fluid/Vacuum Port Fitting 1/2", 3/4", or 1" Barbed Hose	
Air Supply Pressure. 60 psig (4.2 kg/cm ²) Min.	
Air Port Fitting 1/4" Dia. one Touch Connectors	
Flow Capacity Fluid or Vacuum. 9.3 Cv Typical Overflow 0.7 Cv Typical	

Tool Flow Rates:
(Based on Standard Design)

25 PSI (1.75kg/cm)		
Hose	L/ sec	GPM
3/4"	1.58	25.1
1"	1.74	27.6

PATENTS:

This tool is manufactured under U.S Patent No. 6,257,285.



Production Control Units, Inc.

2280 West Dorothy Lane, Dayton, Ohio 45439-1892 Phone (937) 299-5594 FAX: (937) 299-4843
©Production Control Units, Inc. U.S.A. Web: www.pcuinc.com