



Series 116 Fuel Test Tool

FEATURES

- Simple attachment
- Air operated valve
- Clamp and seal detection
- Drip free operation
- High fluid flow rate
- Automated disconnect
- Fail safe operation
- Rugged & durable construction
- Easily maintained
- Light Weight



The PCU Compufill Series 116 Fuel Fill Tool connects to engine fuel systems for leak test and/or filling. This tool adapts the filling equipment to the fuel system.

The PCU Compufill Series 116 tool can be operated in conjunction with all PCU and other compatible fuel fill machines. This series of tools includes models which can be attached to most common fuel fill necks.

Typical tool operation is semi-automatic in that the operator has only to locate the tool onto the fill neck. Upon initiation of the fill cycle, the tool, under control of the fill machine will automatically seat and seal check for proper clamping before leak check, and filling operation can proceed.

Upon completion of these operations, the tool unseats and can then be retracted. All models are designed to provide minimum drip operation.

The PCU Compufill Series 116 tool provides flexibility from manual operations to those which are fully automated when attached to an tool presentation arm.

Series 116 tools can be easily modified to meet your applications. Contact our Order Department at (1-937-299-5594) for your application requirements.

Series 116 Fuel Test Tool

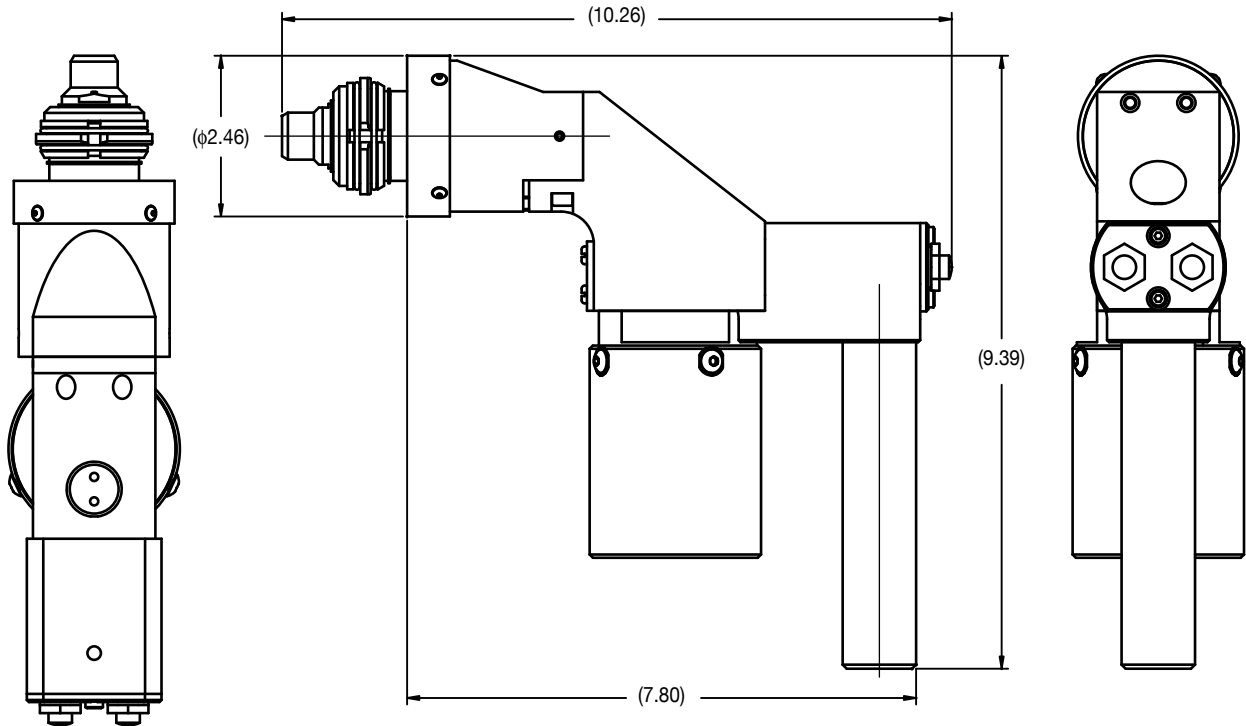

- Tools can be used with PCU tool presentation arms for manual connect - pick and place - semi-auto attachment to vehicle reservoirs.
- Fits large and small fuel necks.
- Large internal porting for high flow rate.
- Tool designs for volume fill.
- Tools are built with spring returns on the valve ports for fail-safe operation during power loss.
- Tool design includes the ability to detect if properly clamped on fill neck.
- All phases of fill cycle internal to tool are automatically controlled by the fill machine.
- Tools are compatible for intrinsically safe operation with programmable logic, relay, or computer based control systems.
- Interfaces to the Compufill Series 116 tool include clamp, seal and valve control air, and fluid air.
- A robust design and durable construction work well in a constant use production environment.
- Aluminum and stainless steel construction are used to minimize weight and eliminate corrosion.

TECHNICAL SPECIFICATIONS:

Weight 4.57 lbs	Flow Capacity 2.93 Cv Typical
Fluid Petrol	Maximum Fluid Pressure 30 psi
Fluid Port Fitting (female) 3/4" NPT (Other sizes are available)	<p>PATENTS: This tool is manufactured under U.S. Patent No. 6,799,614 B1.</p>
Air Supply Pressure 110 psig (7.7 kg/cm ²) Min.	
Air Port Fitting 1/4" Dia. one Touch Connectors	



Production Control Units, Inc.

2280 West Dorothy Lane, Dayton, Ohio 45439-1892 Phone (937) 299-5594 FAX: (937) 299-4843
 ©Production Control Units, Inc. U.S.A. Web: www.sterlingpcu.com